

Scope of Work – Envirodyne Belt Filter Press Repairs

1. Lump sum bid for the work which generally consists of disassembly, removal, inspection, repair, reassembly, installation and alignment of pillow block bearings and the filter press rollers. The work to be performed includes all labor, rigging and equipment necessary to remove and reassemble the bearings and rollers to make the filter press operational.
2. Work will require removal, repair and replacement of twenty-two pillow block bearings on each side of the filter press as shown on drawing. The pillow block bearings support the twenty-two filter press rollers, which are also to be reinstalled. Bearing are to be installed per manufacture recommendations.
3. Work will require removal of all filter press rollers, inspection and repairs to shafts as required in order mate to the tolerance fit on bearing assembly as required. Shaft repairs will be on an as needed basis as determined by Director in consultation with contractor. Shaft repairs shall be completed as unit price per each repaired.
4. Removal and replacement of bearings and rollers may require removal and reinstallation of supports, shields, motors, gear drives, etc., where required for access or removal of bearings and rollers.
5. After completion of above work, county staff will install filter press belts. Filter press will be placed into operation under no load as coordinated with County to insure all bearings and rollers are installed in alignment and running as intended.
6. A plan and profile sheet of the Belt Filter Press is attached.

Materials

1. The County will purchase and provide all bearing assemblies and pillow block housings as required for re-assembly.
2. The County will purchase and provide new filter press belts.
3. The County will provide bearing grease where necessary.

General Provisions

1. **Sealed Bids**; Seal bids will be received at the Wythe County Administration Offices, 340 South Sixth Street, Wytheville, Virginia 24382 until 2:00 P.M. local prevailing time on February 19, 2020. Bidders shall comply with Virginia Code Section 54.1-1112 regarding information required with Bid. Envelopes containing Bids shall be clearly marked with the Bidder's contractor license number. Bids shall be provided on Attachment A.

2. **Licensure**; The contractor must have a Valid State of Virginia business license.
3. **References**; Included in sealed bids, include no less than three references of work experience similar or equal to scope of work to be performed. References shall include name, address, contact number, bid price and type/scope of work completed, start date and completion dates for said work.
4. **Contract**; The County will enter into a contract with the successful bidder within thirty (30) days from the date of bids being due. The contract award will be based on what is in the best interest of the County, including but not limited to the contract price, availability to complete the work and confirmation of references and work experience.
5. **Time for Completion of work**; Work shall be completed within thirty (30) calendar days of notice to proceed, or at a time agreed to between County and contractor. Let it be noted that the press is an integral part of the wastewater process and the work must be completed in an expeditious manner.
6. **Payment**; upon completion of the work and acceptance by the County, payments will be made at the contract lump-sum or unit price. Partial payments shall be made according to percentage of work completed or unit price work completed.
7. **Site Visits**; visiting the site for inspection of the belt filter press and necessary repairs is required in order to bid work. Point of contact to arrange site visit or questions is Mr. Don Crisp, Director, Water and Wastewater at phone (276) 223-4500 or email dtcrisp@wytheco.org.

Contractor List of References

(Provide Three References, copy this form)

1. Name: _____
2. Address; _____
3. Type/Scope of work completed:

4. Contract Amount: _____
5. Start Date: _____
6. Completion Date: _____

ATTACHMENT A

BID FORM

Belt Filter Press Repairs

**Wythe County
340 South 6th Street
Wytheville, VA 24382**

Bids received until: 2:00 pm, local prevailing time on February 19, 2020.

Work	Lump Sum Bid Price
Bearing and Roller remove/replace	\$

Work	Unit Price (each)
Shaft Repairs (each)	\$

Company: _____

Virginia Contractors License Number and Class:

Mailing Address: _____

Telephone: _____

E-mail: _____

Contact Person: _____

Signature: _____

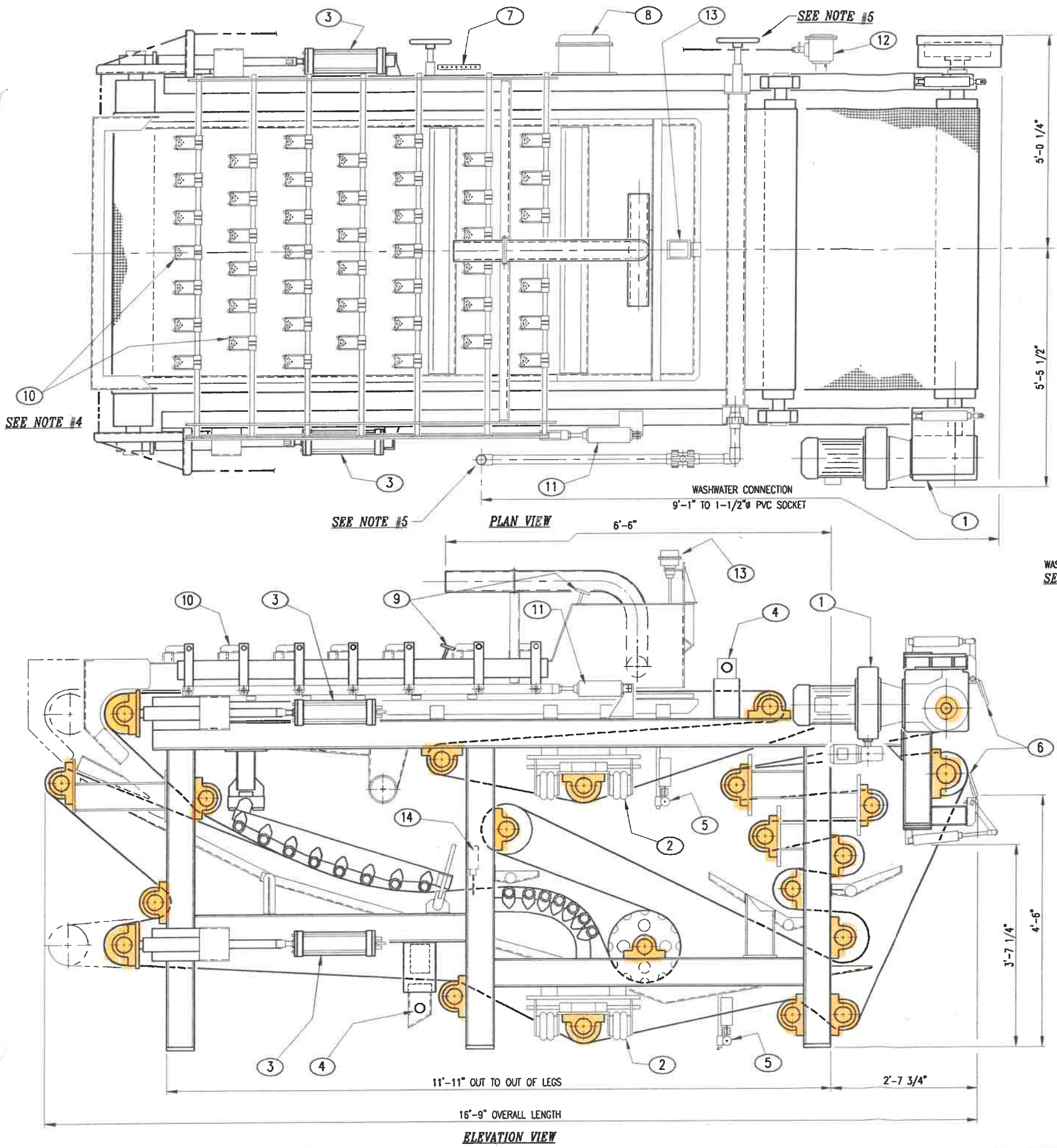

- NOTES:**
1. SAFETY STOP CABLES NOT SHOWN.
 2. DRAIN LINES NOT SHOWN.
 3. MINIMUM CLEAR DISTANCE FROM ONE SIDE OR OTHER OF MACHINE, RECOMMENDED TO BE AT LEAST 80% OF BELT WIDTH TO ALLOW FOR ROLL SERVICING AND MAINTENANCE.
 4. TOTAL QUANTITY OF PLOWS IS DEPENDENT UPON MACHINE WIDTH.
 5. SEE DWG. NO. 600-B-51982 FOR WASHWATER PIPING ARRANGEMENT.

REF.	DESCRIPTION
1	MAIN BELT DRIVE (SHAFT MOUNTED)
2	ALIGNMENT GUIDE ASSEMBLY
3	BELT TENSIONING ASSEMBLY
4	BELT WASH STATION
5	PALM (STEERING) ACTUATOR
6	PNEUMATIC DOCTOR BLADE ASSEMBLY
7	AIR MANIFOLD
8	NEMA 4X JUNCTION BOX
9	ADJUSTABLE LEVELING GATE
10	SLUDGE FURROWING PLOWS
11	PNEUMATIC PLOW LIFTING ASSEMBLY
12	SAFETY STOP SWITCH
13	HEADBOX HIGH SLUDGE LEVEL PROBE
14	BELT OVERTRAVEL LIMIT SWITCH

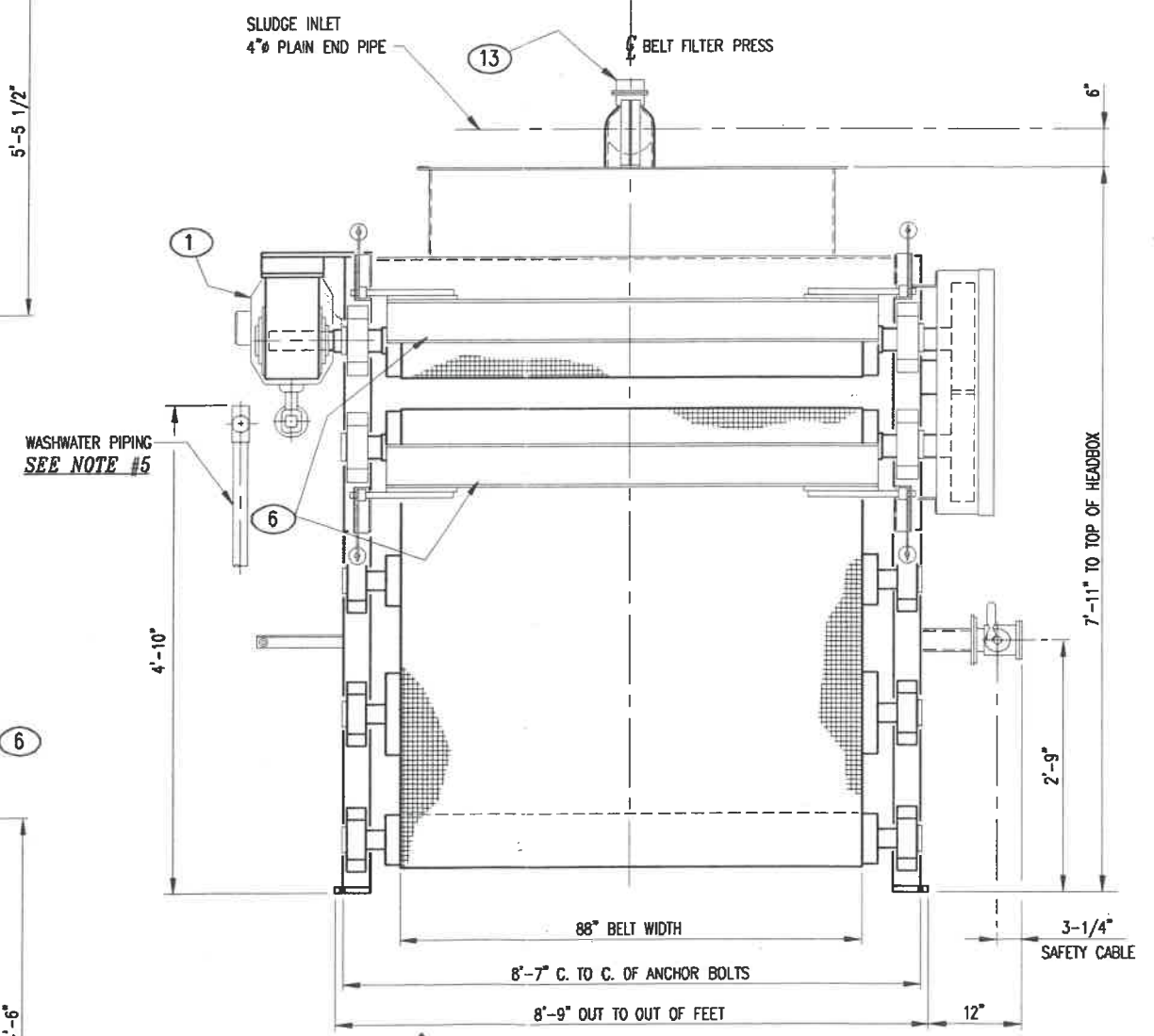

Bearing & Roller

WYTHE COUNTY BOARD OF SUPERVISORS
WYTHE COUNTY, VA

ENVIRODYNE SYSTEMS INC.
Camp Hill, Pennsylvania 17011

TITLE: **GENERAL ARRANGEMENT ALL-AMERICAN™ BELT FILTER PRESS MODEL USV-88 (2.2 METER)**

E.S.I. NOT RESPONSIBLE FOR CONCRETE DESIGN. CONCRETE SHOWN FOR IDENTIFYING PURPOSES ONLY.

SCALE: **1/4" = 1'-0"** DWN. BY: **KAD** DATE: **8/29/06** SHOP ORDER NO. **7272(A)** DRAWING NO. **608-B-54903**